

Manifold Valves • 5-Valve Manifold



5-Valve Manifold

5-Valve Manifold offer two mainline block valves and a double block and bleed valve for the equalizer line. The manifold is primarily intended for gas service and is used to connect differential pressure transmitters to system flow meters. Connections are 1/2" Female NPT on 2-1/8" (54mm) centers. Standard features include two 1/4" NPT static pressure connections on the instrument side and one 1/4" NPT vent connection from the bleed valve.



Equalizer & Bleed Valves

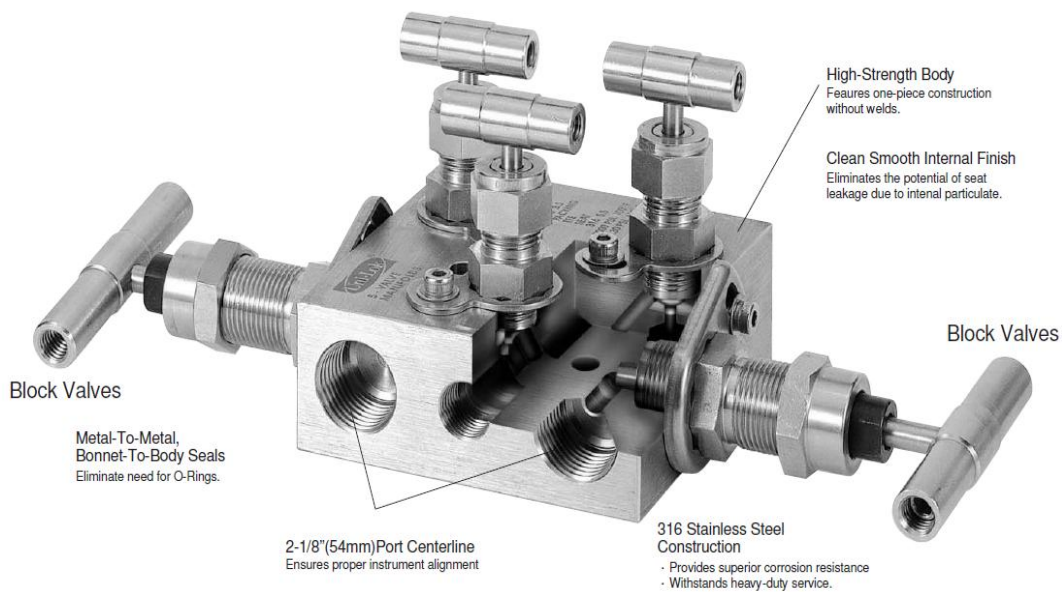

Materials of Constructons

The three Equalizer and Bleed valves have the same material construction as 2VMNT.
The two Block valves have the same material construction as 3VMNT.

Manifold Valves • 5-Valve Manifold

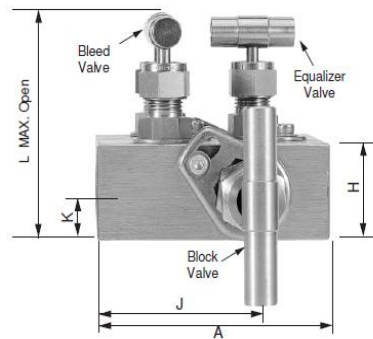
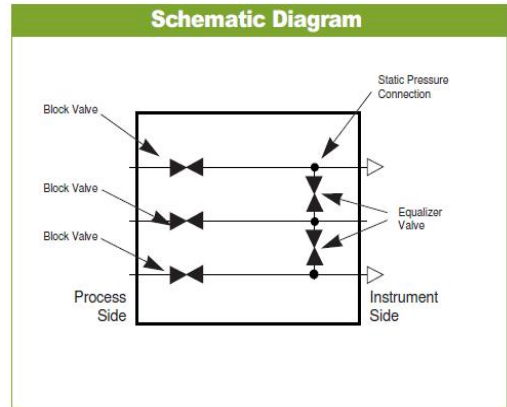
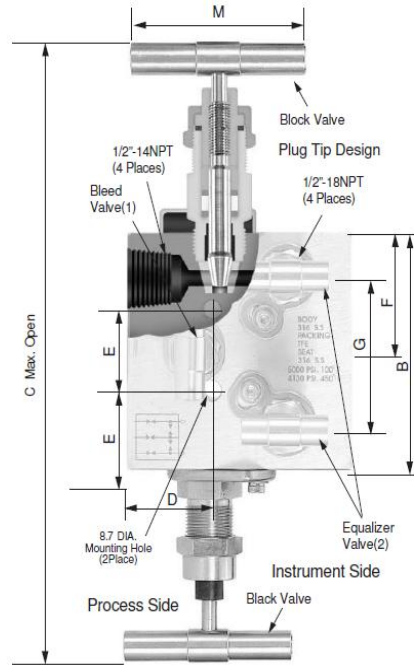

Table of Dimensions

Unit : mm

A	B	C(Open)	D	E	F	G	H	J	K	L(OPEN)	M
86.0	86.0	229.0	40.0	28.6	43	54	34	50	17	82	64.0

Technical Data for Proper Manifold Selection

Unit : mm

Stem Design	Ordering Number	Seat	Pressure Rating	Pressure Rating Max. Temperature	Packing
Needle Tip	5VMNT-8N-SS	316SS	413 bar from -54°C to 38°C (6000psi from -65°F to 100°F)	284 bar @232°C (4130psi @450°F)	PTFE
	5VMNT-8N-FL-SS			118 bar @648°C (1715psi @1200°F)	Grafoil
Plug Tip	5VMNG-8N-SS	Delrin	413 bar from -54°C to 38°C (6000psi from -65°F to 100°F)	68 bar @121°C (1000psi @250°F)	PTFE
	5VMVD-8N-SS			68 bar @121°C (1000psi @250°F)	PTFE
	5VMVD-8N-FL-SS				