

uni-primet[®]
CLEAN JOINT SYSTEM

**CYLINDER
CONNECTORS**



CGA/DISS/JIS type Cylinder Connections are used to connect High Purity Specialty gases in process application.

Special Features

All types have specially designed and patented Bearings for easy installation. Materials of glands are High Purity Stainless Steel for Higher Weldability. Internal surfaces of glands are electro polished. Strict visual inspection of critical surfaces. All parts are cleaned with DI water in a certified cleanroom. Assembled and packed in a certified cleanroom also. Nipples have standard w/wrench flats. Gaskets are available in PCTFE, PTFE and Nickel.

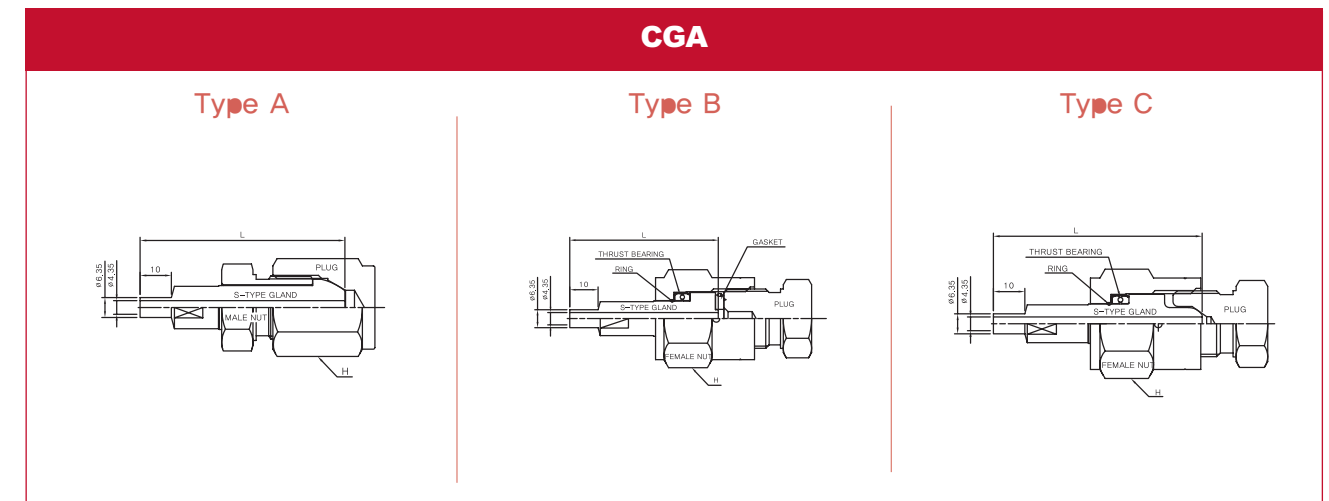
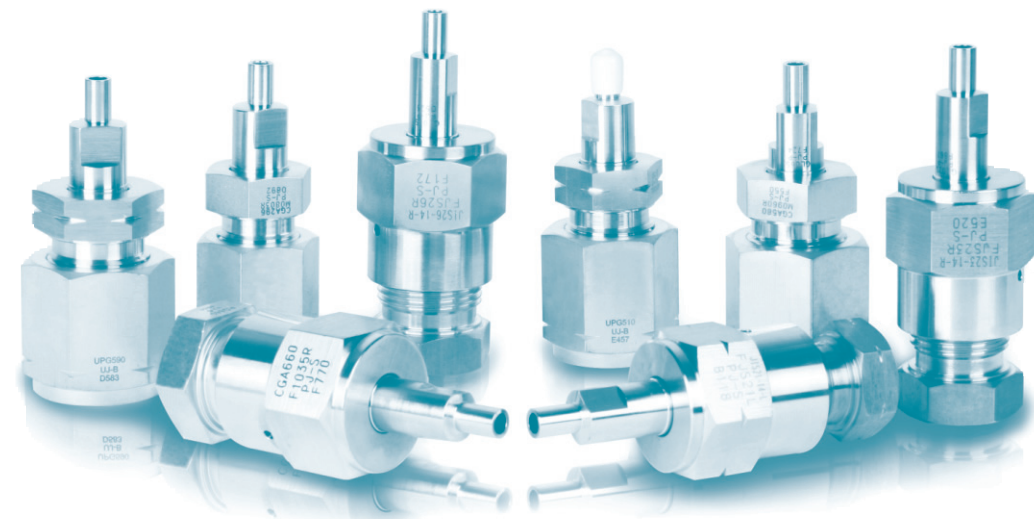

Parts List - CGA

CGA Number	TYPE	L Overall Length		H Flat Bar	Nut Part Number	Bearing Part Number	Gland Part Number	Gasket Part Number	
		inch	mm					PCTFE	Nickel
CGA296	A	2.57	65.3	15/16	UM-0803R	-	UGL-08S	-	-
CGA320	B	2.03	51.5	1-3/16	UF-0830R	UBR-01	UGL-01S	-	UGT01A
CGA326	C	2.61	66.2	1-3/16	UF-0830R	UBR-01	UGL-04S	-	-
CGA330	B	2.03	51.5	1-3/16	UF-0830L	UBR-01	UGL-01S	-	UGT01A
CGA350	C	2.63	66.8	1-3/16	UF-0830L	UBR-01	UGL-05S	-	-
CGA510	A	2.57	65.3	15/16	UM-0880L	-	UGL-06S	-	-
CGA540	C	2.63	66.7	1-3/16	UF-0908R	UBR-01	UGL-09S	-	-
CGA580	A	2.57	65.3	1-1/16	UM-0960R	-	UGL-06S	-	-
CGA590	A	2.57	65.3	1-1/16	UM-0960L	-	UGL-06S	-	-
CGA660	B	2.13	54.0	1-1/4	UF-1035R	UBR-02	UGL-03S	-	UGT03A
CGA670	B	2.13	54.0	1-1/4	UF-1035L	UBR-02	UGL-03S	-	UGT03A
CGA678	B	2.44	62.1	1-1/4	UF-1035L	UBR-02	UGL-07S	-	UGT01B
CGA679	B	2.38	60.4	1-1/4	UF-1035L	UBR-02	UGL-10S	-	UGT05B

Note : Dimensions are reference only, subject to change without prior notice.

Cylinder Connectors JIS / DISS

Cylinder Connectors GLAND / Bearing / NUT

JIS

Type B

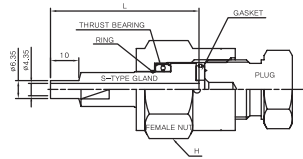

Parts List - JIS

JISS Number	TYPE	L Overall Length		H Flat Bar	Nut Part Number	Bearing Part Number	Gland Part Number	Gasket Part Number	
		inch	mm					PCTFE	Nickel
JIS21-14-L	B	2.03	51.5	1-3/16	UF-JS21L	UBR-01	UGL-11S	-	UGT02A
JIS21-14-R	B	2.03	51.5	1-3/16	UF-JS21R	UBR-01	UGL-02S	-	UGT02A
JIS22-14-L	B	2.03	51.5	1-3/16	UF-JS22L	UBR-01	UGL-02S	-	UGT02A
JIS22-14-R	B	2.03	51.5	1-3/16	UF-JS22R	UBR-01	UGL-02S	-	UGT02A
JIS23-14-R	B	2.03	51.5	1-3/16	UF-JS23R	UBR-01	UGL-02S	-	UGT02A
JIS26-14-L	B	2.13	54.0	1-1/4	UF-JS26L	UBR-02	UGL-02S	-	UGT03A
JIS26-14-R	B	2.13	54.0	1-1/4	UF-JS26R	UBR-02	UGL-02S	-	UGT03A

DISS

Type D

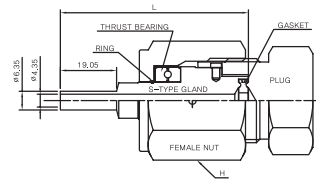

Parts List - DISS

DISS Number	TYPE	L Overall Length		H Flat Bar	Nut Part Number	Bearing Part Number	Gland Part Number	Gasket Part Number	
		inch	mm					PCTFE	Nickel
DISS632	D	2.51	63.8	1-1/4	UF-1035R	UBR-02	UGL-632	DISS-UNGT	DISS-UGT
DISS634	D	2.51	63.8	1-1/4	UF-1035R	UBR-02	UGL-634	DISS-UNGT	DISS-UGT
DISS636	D	2.51	63.8	1-1/4	UF-1035R	UBR-02	UGL-636	DISS-UNGT	DISS-UGT
DISS638	D	2.51	63.8	1-1/4	UF-1035R	UBR-02	UGL-638	DISS-UNGT	DISS-UGT
DISS640	D	2.51	63.8	1-1/4	UF-1035R	UBR-02	UGL-640	DISS-UNGT	DISS-UGT
DISS642	D	2.51	63.8	1-1/4	UF-1035R	UBR-02	UGL-642	DISS-UNGT	DISS-UGT
DISS712	D	2.51	63.8	1-3/8	UF-1130R	UBR-02	UGL-712	DISS-UNGT	DISS-UGT
DISS714	D	2.51	63.8	1-3/8	UF-1130R	UBR-02	UGL-714	DISS-UNGT	DISS-UGT
DISS716	D	2.51	63.8	1-3/8	UF-1130R	UBR-02	UGL-716	DISS-UNGT	DISS-UGT
DISS718	D	2.51	63.8	1-3/8	UF-1130R	UBR-02	UGL-718	DISS-UNGT	DISS-UGT
DISS720	D	2.51	63.8	1-3/8	UF-1130R	UBR-02	UGL-720	DISS-UNGT	DISS-UGT
DISS722	D	2.51	63.8	1-3/8	UF-1130R	UBR-02	UGL-722	DISS-UNGT	DISS-UGT
DISS724	D	2.51	63.8	1-3/8	UF-1130R	UBR-02	UGL-724	DISS-UNGT	DISS-UGT
DISS726	D	2.51	63.8	1-3/8	UF-1130R	UBR-02	UGL-726	DISS-UNGT	DISS-UGT
DISS728	D	2.51	63.8	1-3/8	UF-1130R	UBR-02	UGL-728	DISS-UNGT	DISS-UGT

Note : Dimensions are reference only, subject to change without prior notice.

GLAND

GLAND A

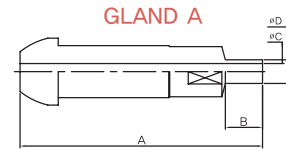

GLAND B

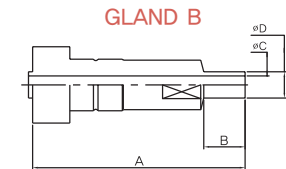

GLAND C

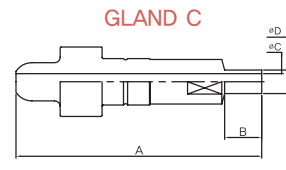

GLAND D

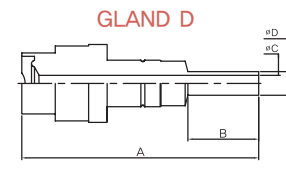

Bearing

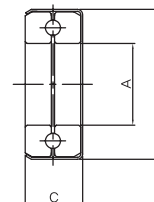

NUT

Female NUT

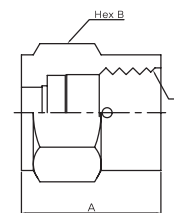

Male NUT

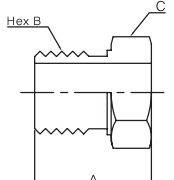

Part No.	A	B	C	D
UGL06S	65.30	10.00	4.35	6.35
UGL08S	65.30	10.00	4.35	6.35

Part No.	A	B	C	D	Part No.	A	B	C	D
UGL01S	52.50	10.00	4.35	6.35	UGL07S	66.06	10.00	4.35	6.35
UGL02S	55.50	10.00	4.35	6.35	UGL10S	66.70	10.00	4.35	6.35
UGL03S	58.00	10.00	4.35	6.35	UGL11S	55.50	10.00	4.35	6.35

Part No.	A	B	C	D
UGL04S	66.20	10.00	4.35	6.35
UGL05S	66.80	10.00	4.35	6.35
UGL09S	66.70	10.00	4.35	6.35

Part No.	A	B	C	D	Part No.	A	B	C	D
DISS-GL632	63.80	19.05	4.35	6.35	DISS-GL716	63.80	19.05	4.35	6.35
DISS-GL634	63.80	19.05	4.35	6.35	DISS-GL718	63.80	19.05	4.35	6.35
DISS-GL636	63.80	19.05	4.35	6.35	DISS-GL720	63.80	19.05	4.35	6.35
DISS-GL638	63.80	19.05	4.35	6.35	DISS-GL722	63.80	19.05	4.35	6.35
DISS-GL640	63.80	19.05	4.35	6.35	DISS-GL724	63.80	19.05	4.35	6.35
DISS-GL642	63.80	19.05	4.35	6.35	DISS-GL726	63.80	19.05	4.35	6.35
DISS-GL712	63.80	19.05	4.35	6.35	DISS-GL728	63.80	19.05	4.35	6.35
DISS-GL714	63.80	19.05	4.35	6.35					

Part No.	A	B	C
UBR01	12.80	18.50	5.70
UBR02	12.80	23.50	9.00

Part No.	A	Hex B	C	Part No.	A	Hex B	C
UF0830R	35.00	30.00	0.830-14NGO-RH-INT	UFJS22R	35.00	30.00	JIS22-14-OR
UF0830L	35.00	30.00	0.830-14NGO-LH-INT	UFJS22L	35.00	30.00	JIS22-14-OL
UF0908R	35.00	30.00	0.830-14NGO-RH-INT	UFJS23R	35.00	30.00	JIS23-14-OR
UF1035R	36.00	32.00	1.035-14NGO-RH-INT	UFJS26R	36.00	32.00	JIS26-14-OR
UF1035L	36.00	32.00	1.035-14NGO-LH-INT	UFJS26L	36.00	32.00	JIS26-14-OL
UFSJ21R	35.00	30.00	JIS21-14-OR	DISS-UF1035R	36.00	32.00	1.035-14NGO-RH-INT
UFJS21L	35.00	30.00	JIS21-14-OL	DISS-UF1130R	36.00	35.00	1.125-14NGO-RH-INT

Part No.	A	B	C
UM0960R	29.00	27.00	0.960-14NGO-RH-EXT
UM0960L	29.00	27.00	0.960-14NGO-LH-EXT
UM0803R	29.00	24.00	0.803-14UNS-2A-RH-EXT
UM0880L	29.00	24.00	0.988-14BGO-RH-INT

Note : Dimensions are in mm and reference only, subject to change without prior notice.

Uni-Tank Cylinder Connectors **PLUG / GASKET**

PLUG

Female Plug

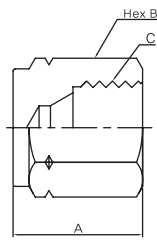

Male Plug

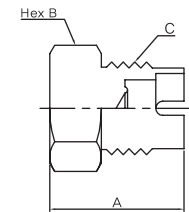
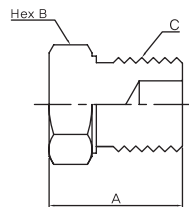

Part No.	A	Hex B
UPG296	32.50	27.00
UPG510	32.50	30.00
UPG580	32.50	32.00
UPG590	32.50	32.00

Part No.	A	Hex B	Part No.	A	Hex B
UPG320	31.00	24.00	UPG679	26.00	29.00
UPG326	30.00	24.00	UPG21R	31.00	24.00
UPG330	31.00	24.00	UPG21L	31.00	24.00
UPG350	30.00	24.00	UPG22R	31.00	24.00
UPG540	30.00	27.00	UPG22L	31.00	24.00
UPG660	26.00	29.00	UPG23R	31.00	26.00
UPG670	26.00	29.00	UPG26R	31.00	29.00
UPG678	26.00	29.00	UPG26L	31.00	29.00

Part No.	A	B	C	Part No.	A	B	C
DISS-PG632	39.00	32.00	1.030-14NGO-RH-EXT	DISS-PG716	39.00	32.00	1.125-14NGO-RH-EXT
DISS-PG634	39.00	32.00	1.030-14NGO-RH-EXT	DISS-PG718	39.00	32.00	1.125-14NGO-RH-EXT
DISS-PG636	39.00	32.00	1.030-14NGO-RH-EXT	DISS-PG720	39.00	32.00	1.125-14NGO-RH-EXT
DISS-PG638	39.00	32.00	1.030-14NGO-RH-EXT	DISS-PG722	39.00	32.00	1.125-14NGO-RH-EXT
DISS-PG640	39.00	32.00	1.030-14NGO-RH-EXT	DISS-PG724	39.00	32.00	1.125-14NGO-RH-EXT
DISS-PG642	39.00	32.00	1.125-14NGO-RH-EXT	DISS-PG726	39.00	32.00	1.125-14NGO-RH-EXT
DISS-PG712	39.00	32.00	1.125-14NGO-RH-EXT	DISS-PG728	39.00	32.00	1.125-14NGO-RH-EXT
DISS-PG714	39.00	32.00	1.125-14NGO-RH-EXT				

NUT

Gasket with SUS Ring

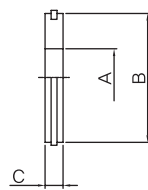

Diss Gasket

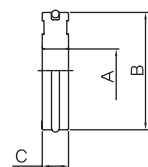

Gasket

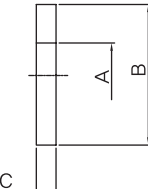

Part No.	A	B	C
UGT01A	12.80	18.50	5.79
UGT02A	12.80	23.50	9.00
UGT03A	12.80	23.50	9.00

Part No.	A	B	C
DISS-UGT	5.40	14.30	3.20
DISS-UNGT	5.40	14.30	3.20

Part No.	A	B	C
UGT01B	7.50	15.40	1.60
UGT05B	8.00	13.50	1.60

Note : Dimensions are in mm and reference only,subject to change without prior notice

Uni-Tank Cylinder Connectors **Gases Assignment Table**

Gases Assignment Table

GAS	UHP CGA/DISS	CGA	JIS	GAS	UHP CGA/DISS	CGA	JIS
Ammonia	720	660	22-R	Hydrogen Iodide	670	330	
Argon	718	580	22/23-R	Hydrogen Selenide	632	350	
Arsenic Pentafluoride	642			Hydrogen Sulfide	722	330	
Arsine	632	350	22-L	Isobutane		510	
Boron Trichloride	634	660	22-L	Isobutylene		510	23-L
Boron Trifluoride	642	330	22-L	Krypton	718	510	22/23-R
Bromochlorodifluoromethane		660		Neon	718	580	22/23-R
Bromotrifluoromethane		660		Nitrogen	718	580	22/23-R
Butane		510	23-L	Nitrous Oxide	712	580	
Carbon Dioxide	716	320		Oxygen	714	740	22/23-R
Carbon Monoxide	724	350	22-L	Perfluoropropane	716	660	
Carbonyl Sulfide		330		Phosgene		660	26-R
Chlorine	728	660	26-R	Phosphine	632	350	
Chlorine Trifluoride		670	26-L	PhosphorusPentafluoride	642	330	
Chlorodifluoromethane		660		Silane	632	350	
Chlorotrifluoromethane		660		Silicon Tetrachloride	636		
Diborane	632	350	22-L	Silicon Tetrafluoride	642	330	
Dichlorodifluoromethane	716	660		Sulphur Dioxide	660	10, 16	
Dichlorofluoromethane		660		Sulphur Hexafluoride	716	326	
Dichlorosilane	636	678		Trichorosilane		636	
Dichlorotetrafluoroethane		660		Trichlorotrifluoroethane	716	660	
Diethylzine	726	510		Trichlorofluoromethane		660	
Difluoroethylene		350	22-L	Triethylaluminium	726	510	
Dimethylzinc	726			Trifluoromethane		660	
Dimethylamine		705	22/26-L	Trimethylamine		705	26-L
Dimethylether		510	26-L	Tungsten Hexafluoride	638	670	
Disilane	632			Vinyl Bromide		510	26-L
Ethane		350	22-L	Vinyl Chloride		510	26-L
Ethyl Chloride		300	26-L	Vinyl Fluoride		350	22-L
Ethylene		350	22-L	Xenon	718	580	22/26-L
Fluorine		679	22-R				
Germane	632	350					
Halocarbons	716	660					
Helium	718	326	22/23-R				
Hydrogen	724	350	22-L				
Hydrogen Bromide	634	330	26-R				
Hydrogen Chloride	634	330	26-R				
Hydrogen Fluoride	638	660	26-R				

This table is only for your reference.

Sources CGA V1 2005 JIS B8244/B8246 1989 ISO/DIS 407 1983



본사 및 공장	Head Office and Factory
인천광역시 남동구 고잔동 725-13번지 남동공단 152블럭 12롯데 TEL:(032)822-6600(대) FAX:(032)821-6604 http://www.unilok.com E-mail : unilok@unilok.com	152 Block-12Lot, Namdong Industrial Complex, 725-13, Gojan-Dong, Namdong-Gu, Incheon, KOREA. TEL:+82-32-822-6600 FAX:+82-32-821-6604 http://www.unilok.com E-mail : unilok@unilok.com

서울직매장	Seoul Office
서울특별시 구로구 구로동 604-1 구로기계공구상가 D-31-110호 TEL:(02)2676-6673(대) FAX:(02)2679-6673	D-31-110, Guro Tools Center, 604-1, Guro-Dong, Guro-Gu, Seoul, KOREA. TEL:+82-2-2676-6673 FAX:+82-2-2679-6673